

Push pull Transformers for DC/DC converters



60 W - 200 kHz

- Based on Microspire's « SESI22 Planar Technology »
- Low-profile SMD package (2x4 pins)
- Applied standards : MIL-STD-202, ECSS-Q-70-02, DO-160D
- Dielectric strength up to 1500V (50Hz-1 min)
- Materials meet UL94-V0 rating
- Thermal index according to IEC85 : H (180 °C)
- Operating/storage temperature range : -55 °C to +125 °C
- Approx weight : 26grams

Electrical Data

ID Code	DC Input Voltage Range (Vdc)	Output Power (W)	Designed Outputs	Working Frequency	Primary Inductance	Insulation > 100MΩ
XXXX22 1W R	17 - 32	60	± 15 Vdc	200 kHz	> 27 μH	500 Vdc

Typical Dimensions (mm, top view)

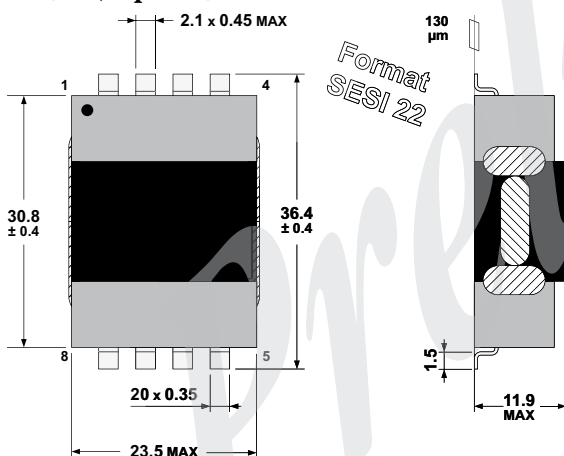

PCB Layout (suggested)

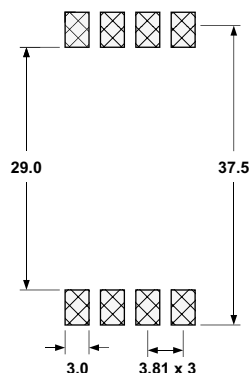

Packaging

Tape and Reel:
100 units per reel of diameter 330 mm

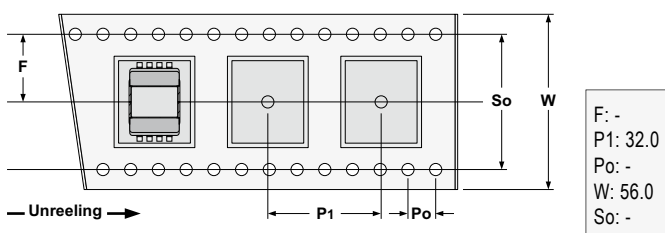

Marking



yyww :
Date code

