

Common-Mode Chokes - CMESC 10-14



- Operating single phase voltage 250 Vrms
- Low strayfield winding structure
- Thermoplastic cases.
- Materials meet with UL94-V0 rating
- Through hole design
- Operating temperature range: -40°C to +70°C

Electrical Data

ID Code	In A	Ln mH ± 30%	Rdc Typ Ω
CMESC10 47M 1X	0.3	47	1.60
CMESC10 39M 1X	0.4	39	1.20
CMESC10 27M 1X	0.5	27	0.60
CMESC10 18M 1X	0.55	18	0.50
CMESC10 15M 1X	0.6	15	0.45
CMESC10 10M 1X	0.8	10	0.20
CMESC10 6M8 1X	1.2	6.8	0.15
CMESC10 3M3 1X	1.5	3.3	0.09
CMESC10 2M0 1X	2.0	2.0	0.06
CMESC11 47M 1X	0.4	47	1.20
CMESC11 39M 1X	0.5	39	0.90
CMESC11 27M 1X	0.8	27	0.60
CMESC11 18M 1X	0.9	18	0.50
CMESC11 15M 1X	1.0	15	0.30
CMESC11 10M 1X	1.2	10	0.20
CMESC11 6M8 1X	1.5	6.8	0.10
CMESC11 3M3 1X	2.5	3.3	0.07
CMESC11 2M0 1X	3.0	2.0	0.04
CMESC12 47M 1X	0.6	47	0.90
CMESC12 39M 1X	0.7	39	0.70
CMESC12 27M 1X	0.8	27	0.50
CMESC12 18M 1X	1.0	18	0.35
CMESC12 15M 1X	1.2	15	0.25
CMESC12 10M 1X	1.5	10	0.15
CMESC12 6M8 1X	2.0	6.8	0.10
CMESC12 3M3 1X	4.0	3.3	0.04
CMESC12 2M0 1X	6.0	2.0	0.02
CMESC13 47M 1X	0.8	47	0.70
CMESC13 39M 1X	1.0	39	0.60
CMESC13 27M 1X	1.4	27	0.30
CMESC13 18M 1X	1.5	18	0.25
CMESC13 15M 1X	1.7	18	0.20
CMESC13 10M 1X	1.8	10	0.15
CMESC13 6M8 1X	2.2	6.8	0.10
CMESC13 3M3 1X	4.0	3.3	0.04
CMESC13 2M0 1X	6.0	2.0	0.02
CMESC14 47M 1X	2.0	47	0.35
CMESC14 39M 1X	2.3	39	0.25
CMESC14 27M 1X	2.5	27	0.20
CMESC14 18M 1X	3.0	18	0.15
CMESC14 15M 1X	3.5	15	0.10
CMESC14 10M 1X	4.0	10	0.09
CMESC14 6M8 1X	5.0	6.8	0.05
CMESC14 3M3 1X	8.0	3.3	0.02
CMESC14 2M0 1X	10.0	2.0	0.01

Connections

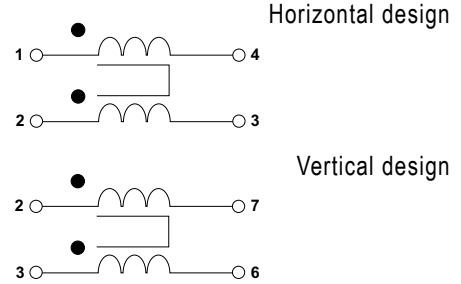

Typical Dimensions (mm)

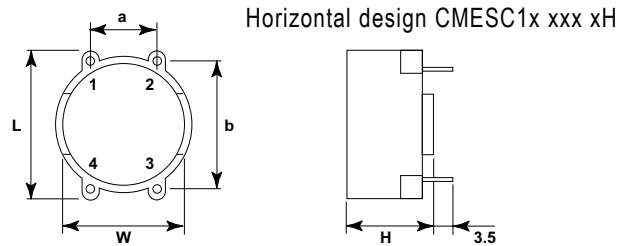

ID Code	L	H	W	A	B	pins
CMESC10 xxx xH	17.5	12.5	17	10	15	0.9 x 0.6
CMESC11 xxx xH	22.5	15.0	22	12.5	20	0.9 x 0.6
CMESC12 xxx xH	27.5	17.5	27	15	25	0.9 x 0.6
CMESC13 xxx xH	33.5	19.2	33	20	30	0.7 x 0.7
CMESC14 xxx xH	42.5	24.3	42	15	40	0.7 x 0.7

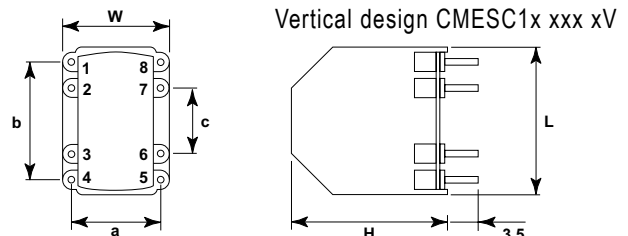

ID Code	L	H	W	A	B	C	pins
CMESC10 xxx xV	17.8	20	12.8	10	15	5	0.9 x 0.6
CMESC11 xxx xV	23	25	15.5	12.5	20	10	0.9 x 0.6
CMESC12 xxx xV	27	30	18	15	22.5	12.5	0.9 x 0.6
CMESC13 xxx xV	32	35	18	15	27.5	12.5	0.9 x 0.6
CMESC14 xxx xV	42	45	28	25	40	25	1.1 x 0.8

Applications

Suppress asymmetric EMI voltages from 10kHz to 10MHz

Industrial Technologies... Power Magnetics... Common Mode EMI Suppression Chokes...



Common-Mode Chokes - CMESC 17



- Less than 20% performance variations versus temperature (-40 °C/+125 °C)
- Minimum impedance attenuation: 100 Ω from 100 kHz to 30 MHz
- RMS current range: from 1.1 A to 11.7 A for 40 °C heating above 25 °C
- All plastics used meet UL94V-0 rating
- Operating/storage temperature range: -40 °C to +125 °C
- Approx weight: 10grams

Electrical Data

ID Code	Inductance Value at 25°C (-40/+35%)	Typical SRF	Max Impedance (Typical)	MAX Attenuation (Z = 50Ω)	MAX RMS Current for ΔT = 40°C	MAX DC Resistance (25°C)	Typical Leakage Inductance (100kHz)
CMESC17 69M 1H	69.2 mH	0.1 MHz	29 kΩ	49 dB	1.1 A	500 mΩ	70 μH
CMESC17 30M 2H	30.3 mH	0.3 MHz	15.8 kΩ	44 dB	1.7 A	220 mΩ	32 μH
CMESC17 13M 1H	13.1 mH	0.6 MHz	9.4 kΩ	40 dB	2.7 A	90 mΩ	13.4 μH
CMESC17 5M8 1H	5.83 mH	1.5 MHz	5.3 kΩ	35 dB	4 A	40 mΩ	6.3 μH
CMESC17 2M6 1H	2.59 mH	8 MHz	3.7 kΩ	32 dB	6 A	18 mΩ	2.3 μH
CMESC17 1M2 1H	1.15 mH	15 MHz	1.9 kΩ	26 dB	8.3 A	10 mΩ	1.1 μH
CMESC17 M45 1H	0.45 mH	32 MHz	1 kΩ	20 dB	11.7 A	5 mΩ	0.5 μH

Dielectric strength test: 500V (50Hz-1min)

Typical Dimensions (mm)

Horizontal design CMESC1x xxx xH

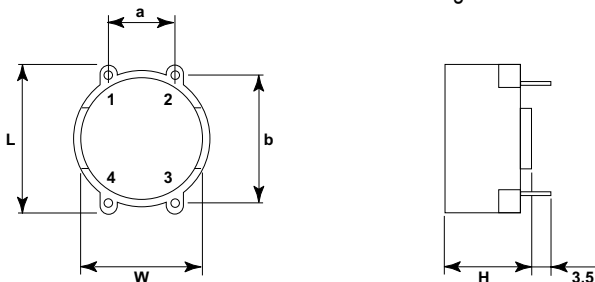

ID Code	L	H	W	A	B	pins
CMESC17 xxx xH	17.5	12.5	17	10	15	0.9 x 0.6

Connections

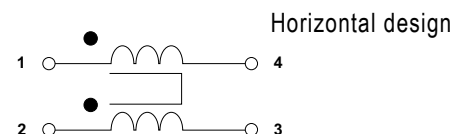

Horizontal design

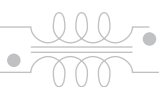

CMESC 17 Common Mode Chokes Series

Improved Temperature Stability

Impedance

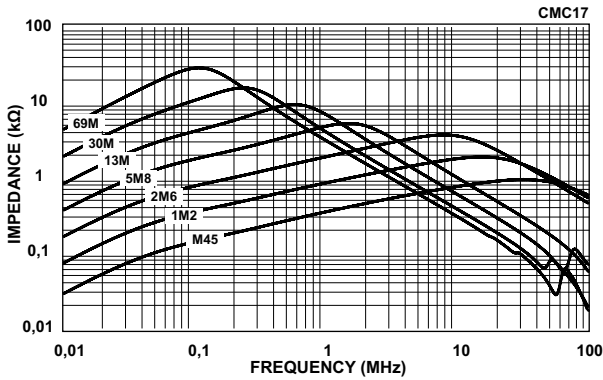

Typical values at 25°C with 1mT at 10kHz

Attenuation

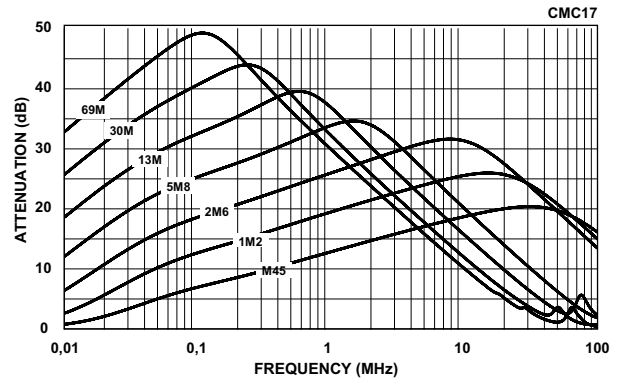

Typical values (Z=50Ω) at 25°C with 1mT at 10kHz

Variation vs Temperature

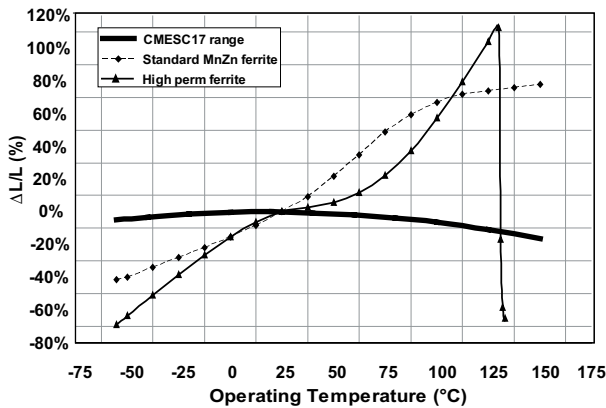

Change in inductance value (<1mT at 10kHz)

Attenuation Measurement Circuit

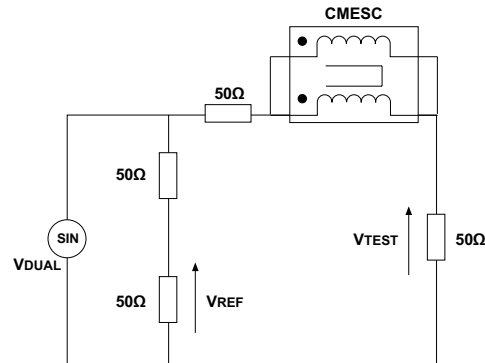

$$\text{Att. (dB)} = 20 \log_{10} \left| \frac{V_{\text{TEST}}}{V_{\text{REF}}} \right|$$

CMESC17 range uses very high performance materials and therefore, offers remarkable temperature stability figures compared to standard or high-perm ferrite cores.

Industrial Technologies... Power Magnetics... Common Mode EMI Suppression Chokes...

