

# Build-to-print Rotors and Stators manufacturing



- Stators, rotors, from 10 to 120mm
- DC-brushless motors, servo motors, linear motors
- High temperature products:
  - Raw Material
  - Impregnation Process

## Operations

1. Design and manufacturing of the specific armature tools
2. Armatures or stator stacks gluing under pressure and varnishing laminations on stacking fixtures
3. Sets of coil winding operations

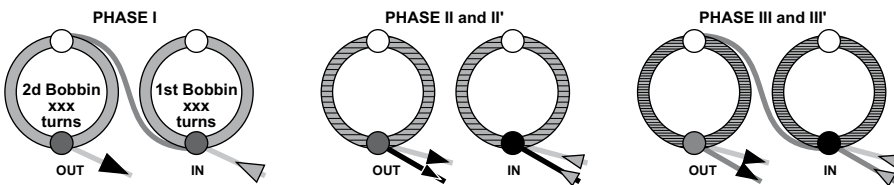

4. Slot insulation positioning, winding insertion into the armature slot, cutting down and folding slot insulation and inserting wedges as each slot is filled.

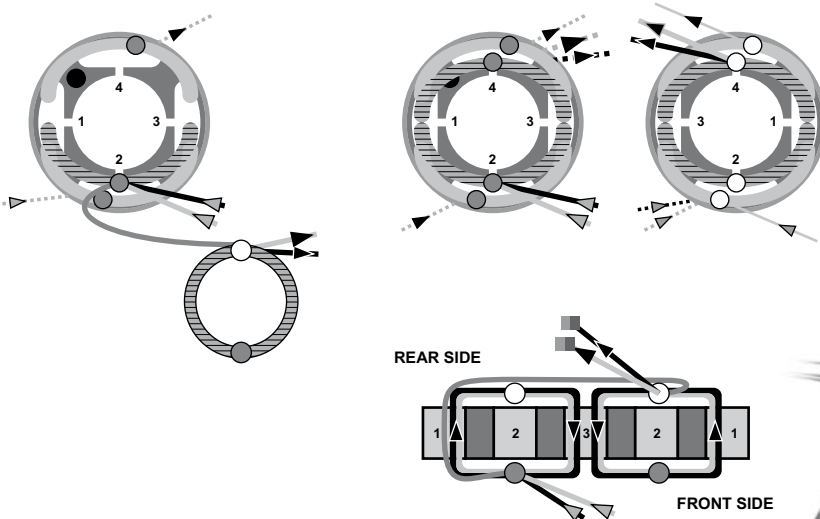

5. Cabling of leadwire with Teflon isolated and flexible sleeve wire, inter-connection of several windings
6. Windings binding and forming against final mechanical dimensions
7. Securing position with lancing tape
8. External rectifying of rotor stacks, internal eroding of stator stacks, notch milling, boring
9. Assembling of the collector and cabling of the winding wires

